

NO.	QTY	DESCRIPTION	MODEL NUMBER				STANDARD SEAL KIT	FKM SEAL KIT
			20-1215-00-US	20-1215-01-US	20-1215-04-US	20-1215-02-US		
1	1	SENSOR, ULTRASONIC, M12, 1m	29740200	29740200	29740200	29740200		
2	1	O-RING, (-029)	39001013	39001013	39001013	39001013	X	39012014
3	1	WIPER, SNAP-IN, (1-1/8)	39050020	39050020	39050020	39050020	X	X
4	1	SEAL, LL, (1-1/8X1/8X1/8X1-3/8)	39011048	39011048	39011048	39011048	X	39012007
5	1	PISTON, CYL, 8800, US	82011014	82011015	82011016	82011017		
6	1	GLAND, CYL, 8800 & 39.9 KN	82031501	82031501	82031501	82031501		
7	1	SEAL, T, (1-5/16 X 5/32 X 1-1/2)	39H11031	39H11031	39H11031	39H11031	X	39V11031
8	1	SENSOR, FACE SEAL	43000040	43000040	43000040	43000040		
	1	SENSOR, FACE SEAL, FKM	43000041	43000041	43000041	43000041		
N/A	N/A	SEAL KIT, STANDARD	60200215	60200215	60200215	60200215	NOTED	
N/A	N/A	SEAL KIT, FKM	6V200214	6V200214	6V200214	6V200214		NOTED

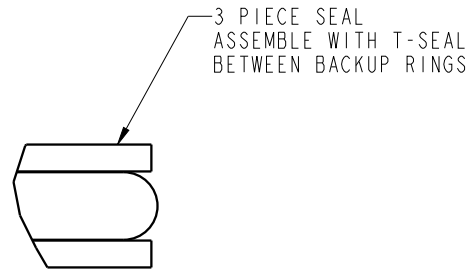

DETAIL A
SCALE 4.000

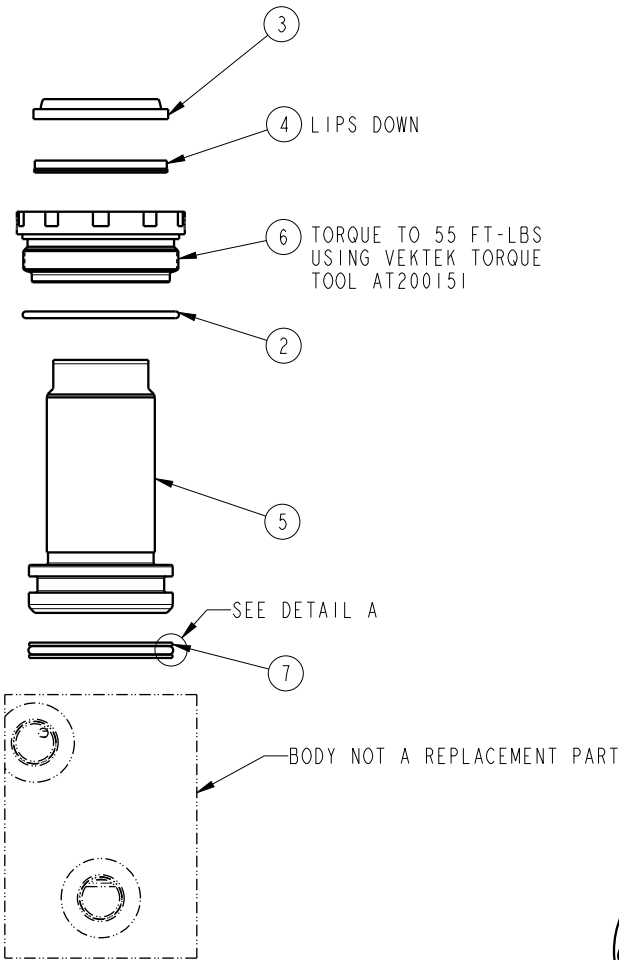

Lubricate all seals with clean hydraulic fluid prior to assembly.

PARTS LIST



VEKTEK, INC.
1334 E. SIXTH AVE. P.O. BOX 625
EMPORIA, KS. 66801 U.S.A.

ASSEMBLIES AFFECTED
20-1215-00-US, 20-1215-01-US
20-1215-04-US, 20-1215-02-US

PARTS LIST, ASSY, CYL, BB, 8800, DA, US

SIZE
A

PL20011

REV
A

SHEET 1 OF 1

FORM FEG035_PL.A.SIZE, REV. B

A	5531	RELEASE	ALS	11/5/24
REV	IN ACCORDANCE WITH ECN	EFFECTIVE DATE	REVISED BY	DATE
DRW BY:	ALS	DRAWING STATUS: Released		
DATE:	10/8/24	PRODUCTION APPROVED FOR RELEASED STATUS ONLY		